



## Gas Convection Ovens 70 and 115 Series

### GENERAL

Single, indirect fired "muffled" oven. 38-1/4" wide x 39-1/2" deep x 61-1/2" high (97.2 x 100.3 x 156.2 cm) overall, including standard gusset-style legs. 27" wide x 27" deep x 20-1/2" high (68.6 x 68.6 x 52.1 cm) interior accommodates 18" x 26" (45.7 x 66 cm) pans lengthwise or widthwise. Used for all purpose baking and roasting. Excellent for reconstitution of frozen foods, (115,000 BTU/HR model).

**DOOR STYLES**, Split-type - each door to have double pane thermal viewing window. A single handle opens both doors.

### MODELS:

70A, 115A - vertical opening doors, side mounted.  
70Z, 115Z - horizontal doors provide shelf for loading/unloading.

### STANDARD FEATURES

- Porcelainized 16 gauge steel interiors.
- Removable 9-position bright nickel rack guides.
- Five 26" x 27" (66 x 68.6 cm) bright nickel racks with rack stop and non-tip feature.
- One fully welded tubular dual steel and cast iron burner.
- 16 gauge stainless steel removable burner baffle.
- 4" (10.2 cm) of insulation compressed to 2" (5.1 cm) within metal sheathing.
- Durable door gaskets, adjustable.

### CONTROLS:

- Suffix G - throttling-type gas thermostat with a temperature adjustment range of 150°F (66°C) to 500°F (260°C), with "Burner-On" indicator light. (Standard for Natural gas.)
- Suffix E- snap acting electric switch-type thermostat with a temperature adjustment range of 200°F (93°C) to 500°F (260°C) with "Burner-On" indicator light. (Standard for Propane gas.)
- Automatic fan shut-off when door is opened. Separate rocker switch for fan operation with oven Cool-Down mode.
- Momentary "On" rocker switch controls two interior oven lights.
- One hour electric timer.

### LEGS:

Gusset-style legs, standard. Black finish.

### OPTIONAL, (\*extra cost):

- \* Enclosed base (cabinet style) w/ 6" (15.2 cm) legs. Black finish.
  - \* S/S front     \* S/S left side     \* S/S right side
  - \* S/S back     \* S/S bottom shelf
  - \* Doors for enclosed base:     \* S/S     \* Black
  - \* 9-position removable rack guides for enclosed base.
- \* Modular Stand (open base) with 4" (10.2 cm) frame. S/S front and lower shelf. 26" (66 cm) S/S legs.
  - \* 9-position removable rack guides for modular base.

### FINISH:

Satin stainless steel front. Remaining exterior black. All painted surfaces have electrolytic zinc undercoating for corrosion protection and longer life.

### OPTIONAL, (\*extra cost):

- Oven:     \*S/S left side     \*S/S right side     \*S/S top  
 \*Louvered back panel:     \*S/S     \*Black
- Gusset-style legs:     \*S/S  
 Flue Deflector:     \*S/S

### MOTOR

Pancake type, air cooled, single speed 3/4 Hp, with thermal overload protection. Sealed, self-lubricating ball bearing requires no lubrication for the life of the bearing. Motor is serviceable from the front through the oven chamber.



115A  
Shown with optional S/S side and top. Optional S/S modular stand with rack guides.

### ELECTRICAL, (\*extra cost):

- 120V, 1Ph, 60Hz, 7.4 amps. 6' (13.5 cm) grounded supply cord.
- 208-240V, 1Ph, 60Hz, 4.1 amps, 3 wire.
- \*208-240V, 3Ph, 60Hz, 3.0 amps, 4 wire.
- \*440-480V, 3Ph, 60Hz, 1.4 amps, 4 wire.
- \*Requires  \*3PH motor with Magnetic Starter on rear of oven.  
 or  \*3PH motor with Magnetic Starter by others.

### OPTIONS, (\*extra cost):

- \*CASTERS - Set of 4
  - Gusset-style Legs: 5" (12.7 cm) stem casters.
  - Enclosed Base: 5" (12.7 cm) plate casters.
  - Modular Stand: 3-1/2" (8.9 cm) stem casters.
- \*DOWN DRAFT DIVERTER, (in-lieu-of std. flue deflector).
  - \*Black     \*S/S
- \*DRIP TRAY, S/S. - (To be placed on oven rack).
- \*ELECTRONIC IGNITION, Suffix EI - available on all ovens with vertical doors.
- \*FLEX CONNECTOR KIT - hose, disconnect and restraining device:     \*3' x 3/4" (91.4 x 1.9 cm)
  - \*4' x 3/4" (122 x 1.9 cm)     \*5' x 3/4" (152 x 1.9 cm)
- \*IFO, (Intermittent Fan Operation) - adjusts for delicate baking. 2-speed motor recommended.
- \*MOIST AIR - Creates steam for bread crusting. Vent included. (Water hook-up required/supplied by others). Not available with IFO or horizontal doors.
- OVEN INTERIOR:
  - \*Full S/S oven lining, including fan baffle, (ASC).
- \*RACKS, EXTRA:
  - \*Standard     \*Extra Heavy (for roasting).
- RACK GUIDES, 11-position.
- \*SECURITY OPTIONS, (prisons, etc). Consult factory.
- SOLID DOORS - (in-lieu-of windows).
- \*SOLID STATE THERMOSTAT.
- \*STEAM JETS - (Steam generator required/supplied by others.)
- \*TWO SPEED MOTOR, 1PH only.
  - \*115V; 11.6 amps @ 1725 rpm, 4.0 amps @ 1140 rpm
  - \*208/240V; 5.9 amps @ 1725 rpm, 2.4 amps @ 1140 rpm



# MONTAGUE 70 and 115 Series

# Gas Vectaire Convection Ovens

Standard configuration available in Montague Auto CAD Foodservice Symbols library.

Dimensions in parenthesis are centimeters.

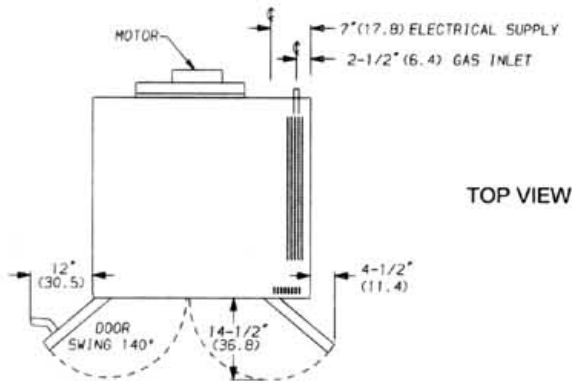

TOP VIEW

RACK SPACING	
# Racks/Oven Section	Clearance
5	3-3/8" (8.6)
9	1-1/2" (3.8)

SUFFIX	DIM "A"
G	1-3/4" (4.4)
E	3-1/2" (8.9)

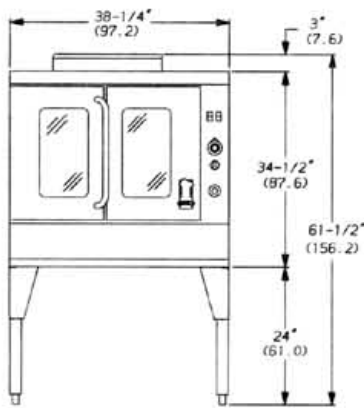

FRONT VIEW - Vertical Doors.  
Shown w/ standard gusset-style legs.

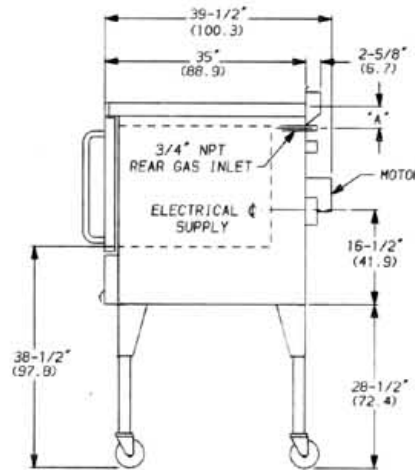

SIDE VIEW - Vertical Doors.  
Shown w/ optional 5" (12.7 cm) casters.

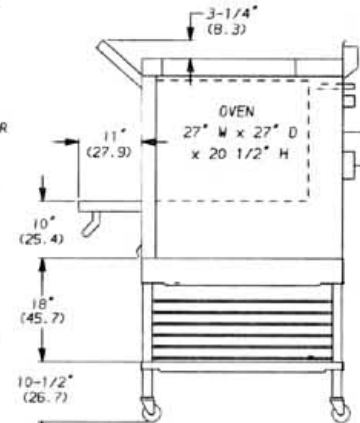

SIDE VIEW - Horizontal Doors.  
Shown w/ optional modular stand with lower shelf, rack guides and 3-1/2" (8.9 cm) casters.

## IMPORTANT

Commercial oven(s) must be installed in accordance with local codes or, in the absence of local codes, with the National Fuel Gas Code ANSI Z223.1. Compliance with codes is the responsibility of the Owner and Installer.

*Adequate Ventilation System required.* Must be installed in accordance with local codes.

**AGA Design Certified:** In accordance with ANSI Z83.12 Gas Foodservice Equipment - Ovens. NOTE: These appliances are intended for commercial use by professionally trained personnel. *NOT Intended For Household Use.*

Minimum Clearances:	Combustible Construction	Noncombustible Construction
Back Wall:	6" (15.2 cm)	5" (12.7 cm)
Left & Right Side:	6" (15.2 cm)	0"
With 24" (61 cm) legs: suitable for installation on combustible floors.		

TYPE OF GAS	Natural	Propane
Manifold Pressure	3.5" WC	10.0" WC
Model	# burners	BTU/HR
All 70	1	70,000
All 115	1	115,000

### GAS INLET SIZE (for all models):

One 3/4" (1.9 cm) NPT at right rear. One 3/4" (1.9 cm) pressure regulator is provided and must be used when appliance is connected to gas supply.

NOTE: Specify type of gas  Natural  Propane  
Specify elevation if installing above 2000 feet.

ENTRY CLEARANCE: 34-3/4" (88.3 cm) uncrated

### APPROX. CUBIC FT/METERS:

Oven, (no base or stand): 37 cu.ft./1.05 m<sup>3</sup>  
Oven w/ gusset-style legs: 37 cu.ft./1.05 m<sup>3</sup>  
Enclosed base: 21 cu.ft./0.59 m<sup>3</sup>  
Modular stand w/ lower shelf & rack guides: 21 cu.ft./0.59 m<sup>3</sup>

### SHIP WGT: (Class 70)

515 Lbs. 234 kg.  
560 Lbs. 254 kg.  
588 Lbs. 267 kg.  
90 Lbs. 41 kg.

*Montague's continuing commitment to quality/product improvement can cause specification and design changes without prior notice.*



## THE MONTAGUE COMPANY

1830 Stearman Avenue, P.O. Box 4954  
Hayward, CA 94540-4954  
Telephone: 800/345-1830 (outside CA)

510/785-8822 FAX: 510/785-3342

<http://www.montague.itrade.net>

Printed in U.S.A.

Vectaire 6  
5291-4 3/97